

UNCONTROLLED

C8415-3

REV. *B*

REVISIONS			
SYM	DESCRIPTION	DATE	APPROV
B	CHNG FINISH PER ECN 1018	1-25-07	<i>R. Oleson</i>

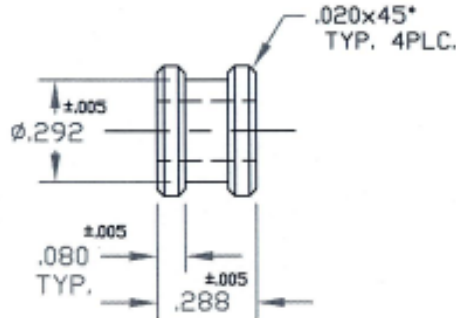
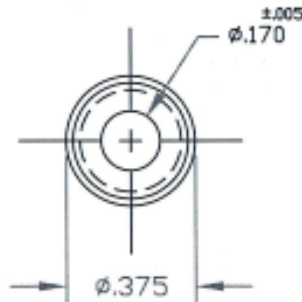

NOTES:

1. FINISH:  
ZINC PLATE PER ASTM-B-633, TYPE III, SC 2, CLEAR TRIVALENT CHROMATE WITH SEALER. (RoHS COMPLIANT) FINISH SUFFIX -Z3CT  
THE ABOVE MENTIONED FINISH WILL BE SUPPLIED AS THE STANDARD FINISH, UPON DEPLETION OF EXISTING STOCK WHICH ARE FINISHED AS FOLLOWS: ZINC PLATE PER ASTM-B-633, TYPE II, SC 2, YELLOW CHROMATE. FINISH SUFFIX -Z3Y.
2. FOR THE APPLICATION OF ALTERNATIVE FINISHES, REMOVE SUFFIX -Z3CT FROM THE PART NO. AND ADD THE REQUIRED FINISH TO THE PART NO. SUFFIX. \*EXAMPLE FOR BLACK ZINC TRIVALENT CHROMATE FINISH, THE PART NO. IS 8415-03-Z3BT.
3. PLEASE VISIT [WWW.DFCIS.COM/C8415-3](http://WWW.DFCIS.COM/C8415-3) FOR A LIST OF AVAILABLE FINISHES.

PART NO.	MATERIAL
8415-03-Z3CT	STEEL (SEE NOTE 3)
8415-03-SS	303 ST. STEEL
8415-03-SS12	304 ST. STEEL

MAT'L <b>AS NOTED.</b>	TOLERANCES ON DIMENSIONS UNLESS OTHERWISE SPECIFIED X = ±2" .XX = ±.015 X/X = ±1/32 .XXX = ±.010 MACHINE FINISH 125T		<b>DFCI SOLUTIONS INC.</b> 425 UNION BOULEVARD WEST ISLIP, NEW YORK 11795	
HEAT TREAT <b>NONE.</b>	PART NO.	DRN <i>S. Francis</i> DATE 12-14-05	TITLE <b>SL-8400 LINE BUSHING, 8415-03-Z3CT.</b>	
FINISH <b>PER NOTE 1.</b>		CHK <i>F. Basch</i> DATE 1-29-07	SIZE <b>A</b>	FSCM NO <b>72794</b>
		ENG <i>R. Oleson</i> DATE 1/30/07	DWG. NO. <b>C8415-3</b>	REV. <b>B</b>
		MFG <i>JS</i> DATE 1-29-07	SCALE <b>NTS</b>	
	NEXT ASSY	USED ON <i>B. Bilal</i> DATE 1/29/07	WT.	SHEET <b>1 OF 1</b>
APPLICATION BLOCK		SALES		

DATE: 07/01/06 FORM: DRAWING