

# UNCONTROLLED

REVISIONS			
SYS	DESCRIPTION	DATE	APPROV
F	PER ECN 1255	01/21/15	F.B

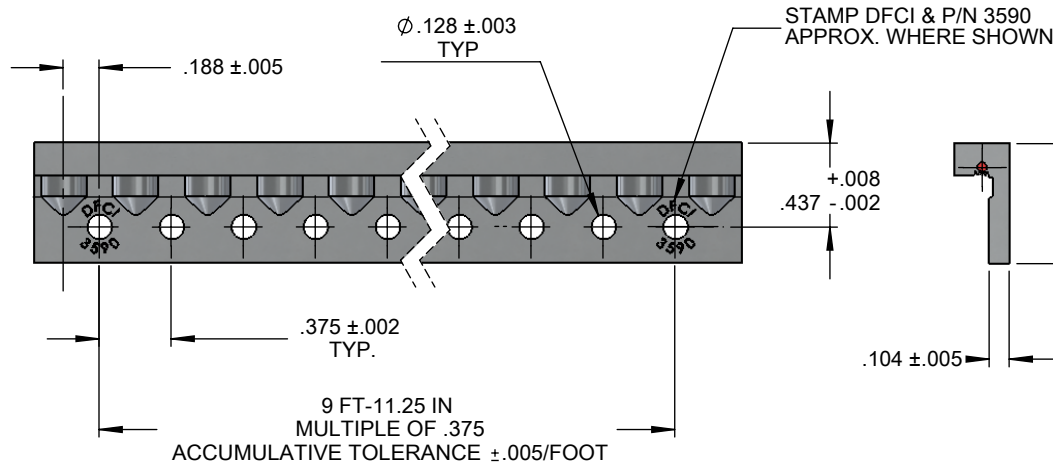
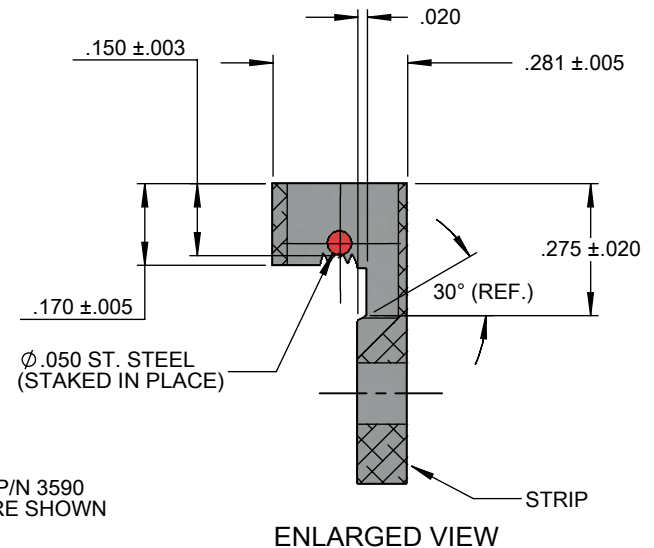
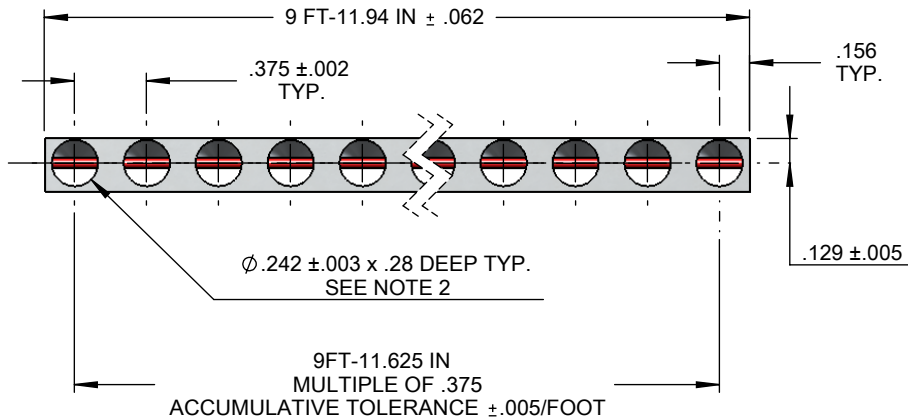

MATERIAL:	PER NOTE 1
HEAT TREAT:	TEMPER COND. T6
FINISH:	SEE NOTE 4
<small>THE FASTENER PARTS SHOWN IN THIS PRINT ARE PROPRIETARY ARTICLES TO WHICH DFCI SOLUTIONS INC., RETAINS THE EXCLUSIVE RIGHTS OF MANUFACTURE, USE AND SALE. THE PRINT OR DRAWING IS SUBMITTED IN CONFIDENCE AND DOES NOT CONVEY A LICENSE OR PERMISSION TO MANUFACTURE THE FASTENER OR FASTENER PARTS.</small>	
<small>(C) COPYRIGHT 2009, DFCI SOLUTIONS INC. ALL RIGHTS RESERVED.</small>	

TOLERANCES ON DIMENSIONS UNLESS OTHERWISE SPECIFIED			
X* = ±2*		.XX = ±.015	
X/X = ±1/32		.XXX = ±.010	
MACHINE FINISH = .125 <input checked="" type="checkbox"/>			
PART NO.	3590-H320	DRN	W. Zhindon
		DATE	06/04/10
		CHK.	<i>Frank Basile</i>
		DATE	06/04/10
		ENG.	<i>Bob Altkorn</i>
		DATE	06/15/10
		MFG.	<i>Bill Velazquez</i>
		DATE	06/15/10
NEXT ASSY	USED ON	Q.C.	<i>Bob Altkorn</i>
		DATE	06/15/10
APPLICATION BLOCK		SALES.	
		DATE	

**DFCI SOLUTIONS INC.**  
 425 UNION BOULEVARD.  
 WEST ISLIP, NEW YORK 11795

TITLE			
<b>PA-3500 LINE RECEPTACLE, 3590-H320</b>			
SIZE	FSCM NO	DWG. NO.	REV
A	72794	C3590	F
SCALE: NTS		WEIGHT:	SHEET 1 OF 2

# UNCONTROLLED

REVISIONS			
SYS	DESCRIPTION	DATE	APPROV
F	PER ECN 1255	01/21/15	F.B

PART NO.	NUMBER OF $\phi$ .242 HOLES PER STRIP
3590-H320	320

NOTES:

- MATERIALS:  
STRIP: 6061-T6 ALUMINUM ALLOY PER QQ-A-200/8  
WIRE:  $\phi$ .050 ST. STEEL TYPE 316, PER ASTM-A-313, SPRING TEMPER
- SOME DISTORSION MAY ENTER THE  $\phi$ .242 HOLE, DUE TO STAKING OF WIRE. THIS WILL NOT AFFECT THE FUNCTION OF THE PRODUCT
- FOR RECEPTACLE LENGTHS SHORTER THAN 9ft-11.94in, REFER TO DRAWING NO. C3590-H
- PLEASE VISIT WWW.DFCIS.COM/C3590 FOR A LIST OF AVAILABLE FINISHES

MATERIAL: PER NOTE 1	TOLERANCES ON DIMENSIONS UNLESS OTHERWISE SPECIFIED X* = $\pm 2^*$ .XX = $\pm .015$ X/X = $\pm 1/32$ .XXX = $\pm .010$ MACHINE FINISH = .125 $\checkmark$			 <b>DFCI SOLUTIONS INC.</b> 425 UNION BOULEVARD. WEST ISLIP, NEW YORK 11795	
HEAT TREAT: TEMPER COND. T6	PART NO. 3590-H320	DRN W. Zhindon	DATE 06/04/10		
FINISH: SEE NOTE 4		CHK. <i>Franz Basile</i>	DATE 06/04/10	TITLE <b>PA-3500 LINE RECEPTACLE, 3590-H320</b>	
THE FASTENER PARTS SHOWN IN THIS PRINT ARE PROPRIETARY ARTICLES TO WHICH DFCI SOLUTIONS INC., RETAINS THE EXCLUSIVE RIGHTS OF MANUFACTURE, USE AND SALE. THE PRINT OR DRAWING IS SUBMITTED IN CONFIDENCE AND DOES NOT CONVEY A LICENSE OR PERMISSION TO MANUFACTURE THE FASTENER OR FASTENER PARTS.  (C) COPYRIGHT 2009, DFCI SOLUTIONS INC. ALL RIGHTS RESERVED.		ENG. <i>Bob Altkorn</i>	DATE 06/15/10		
		MFG. <i>Bill Velazquez</i>	DATE 06/15/10		
	NEXT ASSY	USED ON	Q.C. <i>Bob Altkorn</i>		DATE 06/15/10
	APPLICATION BLOCK	SALES.	DATE	SIZE FSCM NO. DWG. NO. REV <b>A 72794 C3590 F</b>	
			SCALE: NTS	WEIGHT:	SHEET 2 OF 2