

UNCONTROLLED

C3503 SHT. 1of2 REV. 6

REVISIONS			
SYM	DESCRIPTION	DATE	APPROV
G	ADD P/N -8-Z3CT ECN 1077	3-3-08	<i>R. Olesed</i>

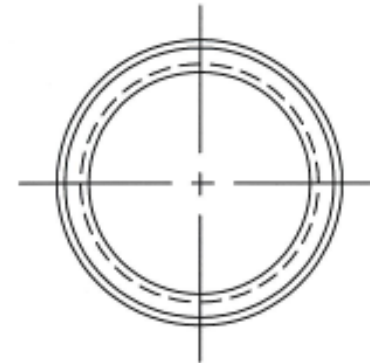
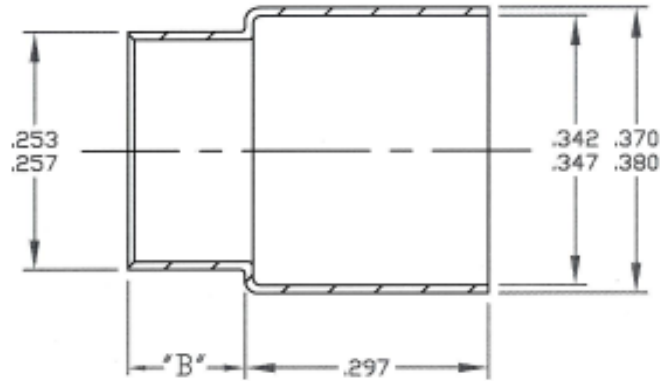

FOR PART NO. REFER TO SHEET 2of2.

MATL A.I.S.I 1008, 1010, 1215, 8620 STEEL OR TYPE 303 ST. STEEL.		TOLERANCES ON DIMENSIONS UNLESS OTHERWISE SPECIFIED $X^* = \pm 2^*$.XX = $\pm .015$ $X/X = \pm 1/32$.XXX = $\pm .010$ MACHINE FINISH 125T		DFCI SOLUTIONS INC. 425 UNION BOULEVARD WEST ISLIP, NEW YORK 11795	
HEAT TREAT ANNEALED.		PART NO.		TITLE PA-3500 LINE CUP, 3503-xx-Z3CT	
FINISH PER NOTE 1.		DRN <i>S. Frazee</i> DATE 10-14-03 CHK <i>F. Basil</i> DATE 3-20-08 ENG <i>R. G. B...</i> DATE 3/20/08 MFG <i>[Signature]</i> DATE 3-20-08		SIZE A FSCM NO 72794 DWG. NO. C3503 REV. G	
<small>THE FASTENER PARTS SHOWN IN THIS PRINT ARE PROPRIETARY ARTICLES TO WHICH DFCS SOLUTIONS INC. RETAINS THE EXCLUSIVE RIGHTS OF MANUFACTURE, USE AND SALE. THE PRINT OR DRAWING IS SUBMITTED IN CONFIDENCE AND DOES NOT CONVEY A LICENSE OR PERMISSION TO MANUFACTURE THE FASTENER OR FASTENER PARTS.</small> <small>© COPYRIGHT 2008 DFCS SOLUTIONS INC. ALL RIGHTS RESERVED.</small>		DATE: 07/01/06 FORM: DRAWING		SALES <i>B. Hinkel</i> DATE 3/20/08 SCALE NTS WT. SHEET 1 OF 2	

The parts shown in this print are proprietary articles to which DFCI Solutions, Inc. retains the exclusive rights of manufacture, use and sale. The print or drawing is submitted in confidence and does not convey a license or permission to manufacture the parts. Copyright © 2008 by DFCI Solutions, Inc. All rights reserved.

UNCONTROLLED

REVISIONS			
SYM	DESCRIPTION	DATE	APPROV
G	ADD P/N-8-Z3CT ENC 1077	3-3-08	<i>R. Oleson</i>

NOTES:

1. FINISH:

ZINC PLATE PER ASTM-B-633, TYPE III, SC 2, CLEAR TRIVALENT CHROMATE WITH SEALER. (RoHS COMPLIANT) FINISH SUFFIX: -Z3CT

THE ABOVE MENTIONED FINISH WILL BE SUPPLIED AS THE STANDARD FINISH, UPON DEPLETION OF EXISTING STOCK WHICH ARE FINISHED AS FOLLOWS: CADMIUM PLATE PER QQ-P-416, TYPE I, CLASS 2, CLEAR CHROMATE. (FINISH SUFFIX: -C3C)

2. FOR PART NO. OF CUP MADE FROM ST. STEEL, REMOVE SUFFIX -Z3CT FROM P/N AND ADD "-SS" EXAMPLE 3503-1-SS.

3. FOR THE APPLICATION OF ALTERNATIVE FINISHES, REMOVE SUFFIX -Z3CT FROM THE PART NO. AND ADD THE REQUIRED FINISH TO THE PART NO. SUFFIX. *EXAMPLE FOR YELLOW ZINC TRIVALENT CHROMATE FINISH, THE PART NO. IS 3503-1-Z3YT.

4. PLEASE VISIT WWW.DFCIS.COM/C3503 FOR A LIST OF AVAILABLE FINISHES.

PART NO.	"B"
3503-Z3CT	.080
3503-1-Z3CT	.090
3503-2-Z3CT	.100
3503-3-Z3CT	.110
3503-4-Z3CT	.120
3503-5-Z3CT	.130
3503-6-Z3CT	.140
3503-7-Z3CT	.070
3503-8-Z3CT	.150
3503-12-Z3CT	.190
3503-15-Z3CT	.220
3503-19-Z3CT	.266

MAT'L A.I.S.I 1008, 1010, 1215, 8620 STEEL OR TYPE 303 ST. STEEL.		TOLERANCES ON DIMENSIONS UNLESS OTHERWISE SPECIFIED $X = \pm 2$.XX = $\pm .015$ $X/X = \pm 1/32$.XXX = $\pm .010$ MACHINE FINISH 125T		 DFCI SOLUTIONS INC. 425 UNION BOULEVARD WEST ISLIP, NEW YORK 11795	
HEAT TREAT ANNEALED.		PART NO.		DRN S. Ferraris DATE 10-14-03	
FINISH PER NOTE 1.		CHK <i>F. Basile</i> DATE 3-20-08		TITLE PA-3500 LINE CUP, 3503-xx-Z3CT	
<small>THE FASTENER PARTS SHOWN IN THIS PRINT ARE PROPRIETARY ARTICLES TO WHICH DFCI SOLUTIONS INC. RETAINS THE EXCLUSIVE RIGHTS OF MANUFACTURE, USE AND SALE. THE PRINT OR DRAWING IS SUBMITTED IN CONFIDENCE AND DOES NOT CONVEY A LICENSE OR PERMISSION TO MANUFACTURE THE FASTENERS OR FASTENER PARTS. COPYRIGHT 2008, DFCI SOLUTIONS INC. ALL RIGHTS RESERVED.</small>		ENG <i>R. Oleson</i> DATE 3/20/08		SIZE A FSCM NO 72794 DWG. NO. C3503 REV. G	
DATE: 07/01/06 FORM: DRAWING		MPG <i>[Signature]</i> DATE 3-20-08		SCALE NTS WT. SHEET 2 OF 2	
NEXT ASSY		USED ON		SALES <i>[Signature]</i> DATE 3/20/08	
APPLICATION BLOCK					