

UNCONTROLLED

C1632-4101 REV. B

REVISIONS			
SYM	DESCRIPTION	DATE	APPROV
B	CHNG OD RETAINER ECN 1027	3-1-07	R. OLSON

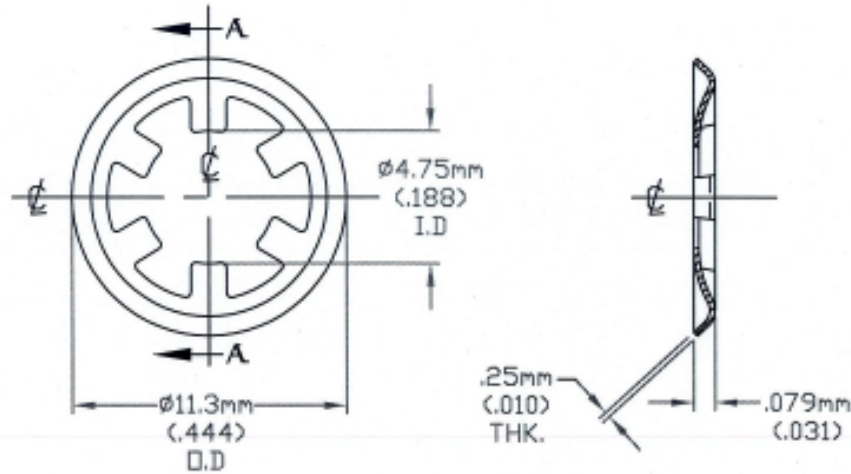

SECTION A - A

SIZE 4 RETAINER
(SEE NOTE 1)

RETAINER P/N	FINISH
1632-4101-Z3CT	ZINC PLATE PER ASTM-B-633, TYPE III, SC 2, CLEAR TRIVALENT CHROMATE.

NOTE:
1. FOR SIZE 6 RETAINER P/N 1632-6101-Z3CT SEE DRAWING NO. C1632-6101.

ALL TOLERANCES ARE IN INCHES

MAT'L HIGH CARBON STEEL.	TOLERANCES ON DIMENSIONS UNLESS OTHERWISE SPECIFIED X = ±2" .XX = ±.015 X/X = ±1/32 .XXX = ±.010 MACHINE FINISH 125		DFCI SOLUTIONS INC. 425 UNION BOULEVARD WEST ISLIP, NEW YORK 11795	
HEAT TREAT SPRING TEMPER.	PART NO.	DRN S. FRANCIS	DATE 11-21-06	TYPE PX-1600 SIZE 4 RETAINER. 1632-4101-Z3CT
FINISH AS NOTED.		CHK F. Basil	DATE 3/2/07	
		ENG R. OLSON	DATE 3/2/07	
		MFG JS	DATE 3/2/07	
		QC B. H. H. H.	DATE 3/2/07	
	NEXT ASSY	USED ON	SALES	DATE
	APPLICATION BLOCK			
			SIZE A	FSCM NO. 72794
			SCALE NTS	WT.
			DWG. NO. C1632-4101	REV. B
			SHEET 1 OF 1	

DATE: 07/01/06 FORM: DRAWING

The parts shown in this print are proprietary articles to which DFCI Solutions, Inc. retains the exclusive rights of manufacture, use and sale. The print or drawing is submitted in confidence and does not convey a license or permission to manufacture the parts. Copyright © 2007 by DFCI Solutions, Inc. All rights reserved.