

UNCONTROLLED

C1631-42 SHT. 1of2 REV. D

REVISIONS			
SYM	DESCRIPTION	DATE	APPROV
D	ADD WEIGHT PER ECN 1110	10-23-08	FB

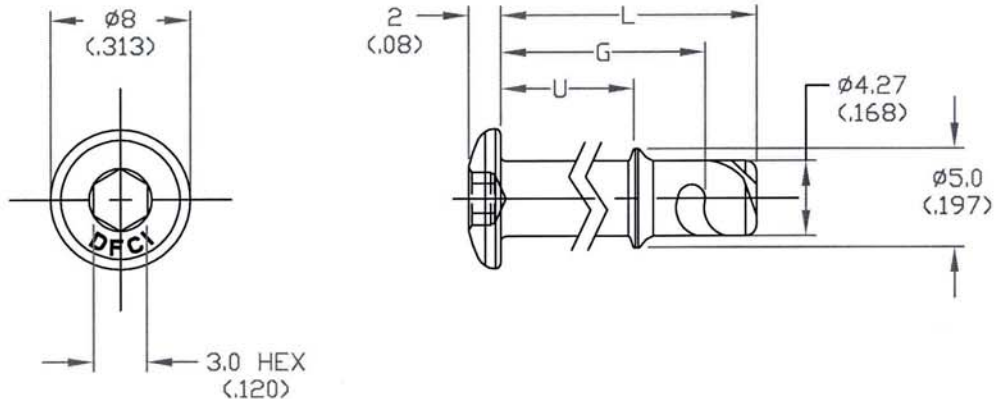

SEE SHEET 2 FOR PART NUMBERS

ALL TOLERANCES ARE IN INCHES

MAT'L A.I.S.I 8620 STEEL.	TOLERANCES ON DIMENSIONS UNLESS OTHERWISE SPECIFIED X° = ±2° .XX = ±.015 X/X = ±1/32 .XXX = ±.010		MACHINE FINISH 125T		DFCI SOLUTIONS INC. 425 UNION BOULEVARD WEST ISLIP, NEW YORK 11795
	HEAT TREAT CASE HARDENED.	PART NO.	DRN S. FRANCOIS DATE 4-10-06	CHK F. Basilio DATE 10-29-08	
FINISH PER NOTE 1.		ENG B. Hildebrand DATE 10/29/08	MFG DATE 10/29/08	SIZE A	FSCM NO 72794
<small>THE FASTENER PARTS SHOWN IN THIS PRINT ARE PROPRIETARY ARTICLES TO WHICH DFCI SOLUTIONS INC. RETAINS THE EXCLUSIVE RIGHTS OF MANUFACTURE, USE AND SALE. THE PRINT OR DRAWING IS SUBMITTED IN CONFIDENCE AND DOES NOT CONVEY A LICENSE OR PERMISSION TO MANUFACTURE THE FASTENER OR FASTENER PARTS.</small> <small>© COPYRIGHT 2003, DFCI SOLUTIONS INC. ALL RIGHTS RESERVED.</small>	NEXT ASSY	USED ON	SALES B. Hildebrand DATE 10/29/08	DWG. NO. C1631-42	REV. D
	APPLICATION BLOCK		SCALE NTS	WT.	SHEET 1 OF 2

DATE: 07/01/06 FORM: DRAWING

UNCONTROLLED

REVISIONS			
SYM	DESCRIPTION	DATE	APPROV
D	ADD WEIGH PER ECN 1110	10-23-08	<i>FB</i>

PART NO.	L	G	U	WEIGHT	
				LBS.	GRAMS
1631-4208-Z3CT	10.5 (.41)	8 (.315)	3 (.12)	.0043	1.950
1631-4209-Z3CT	11.5 (.45)	9 (.354)	4 (.16)	.0046	2.086
1631-4210-Z3CT	12.5 (.49)	10 (.394)	5 (.20)	.0048	2.177
1631-4211-Z3CT	13.5 (.53)	11 (.433)	6 (.24)	.0050	2.268
1631-4212-Z3CT	14.5 (.57)	12 (.472)	7 (.28)	.0053	2.404
1631-4213-Z3CT	15.5 (.61)	13 (.512)	8 (.32)	.0055	2.495
1631-4214-Z3CT	16.5 (.65)	14 (.551)	9 (.35)	.0057	2.585
1631-4215-Z3CT	17.5 (.69)	15 (.590)	10 (.39)	.0060	2.721
1631-4216-Z3CT	18.5 (.73)	16 (.630)	11 (.43)	.0062	2.812
1631-4217-Z3CT	19.5 (.77)	17 (.669)	12 (.47)	.0065	2.948
1631-4218-Z3CT	20.5 (.81)	18 (.709)	13 (.51)	.0067	3.039
1631-4219-Z3CT	21.5 (.85)	19 (.748)	14 (.55)	.0069	3.130
1631-4220-Z3CT	22.5 (.89)	20 (.787)	15 (.59)	.0071	3.220
1631-4221-Z3CT	23.5 (.93)	21 (.827)	16 (.63)	.0074	3.357

NOTES:

- FINISH:
ZINC PLATE PER ASTM-B-633, TYPE III, SC 2., CLEAR TRIVALENT CHROMATE WITH SEALER. (RoHS COMPLIANT)
- PLEASE VISIT www.dfci.com/dzfinish.html FOR A LIST OF AVAILABLE FINISHES.
- ALL PRIMARY DIMENSION ARE IN MILLIMETERS AND DIMENSION SHOWN BETWEEN (xxx) SHOWN ARE IN INCHES.

ALL TOLERANCES ARE IN INCHES

MAT'L A.I.S.I 8620 STEEL.	TOLERANCES ON DIMENSIONS UNLESS OTHERWISE SPECIFIED X* = ±2* .XX = ±.015 X/X = ±1/32 .XXX = ±.010		MACHINE FINISH 125T		 DFCI SOLUTIONS INC. 425 UNION BOULEVARD WEST ISLIP, NEW YORK 11795	
HEAT TREAT CASE HARDENED.	PART NO.	DRN <i>S. Francis</i>	DATE 4-10-06	TITLE PX-1600 SOCKET HD STUD 1631-42xxx-Z3CT		
FINISH PER NOTE 1.		CHK <i>F. Basily</i>	DATE 10-29-08	SIZE A	FSCM NO 72794	DWG. NO. C1631-42
<small>THE FASTENER PARTS SHOWN IN THIS PRINT ARE PROPRIETARY ARTICLES TO WHICH DFCI SOLUTIONS INC. RETAINS THE EXCLUSIVE RIGHTS OF MANUFACTURE, USE AND SALE. THE PRINT OR DRAWING IS SUBMITTED IN CONFIDENCE AND DOES NOT CONVEY A LICENSE OR PERMISSION TO MANUFACTURE THE FASTENER OR FASTENER PARTS.</small> © COPYRIGHT 2003, DFCI SOLUTIONS INC. ALL RIGHTS RESERVED. DATE: 07/01/06 FORM: DRAWING	NEXT ASSY	USED ON <i>B. Wilke</i>	DATE 10/29/08	SCALE NTS	WT.	REV. D
	APPLICATION BLOCK	SALES	DATE	SHEET 2 OF 2		