

UNCONTROLLED

C1224-1031 REV. *D*

| REVISIONS | | | |
|-----------|----------------------------------|---------|------------|
| SYM | DESCRIPTION | DATE | APPROV |
| D | ADD WEIGHT & -SS TO P/N ECN I137 | 3-27-09 | <i>FJB</i> |

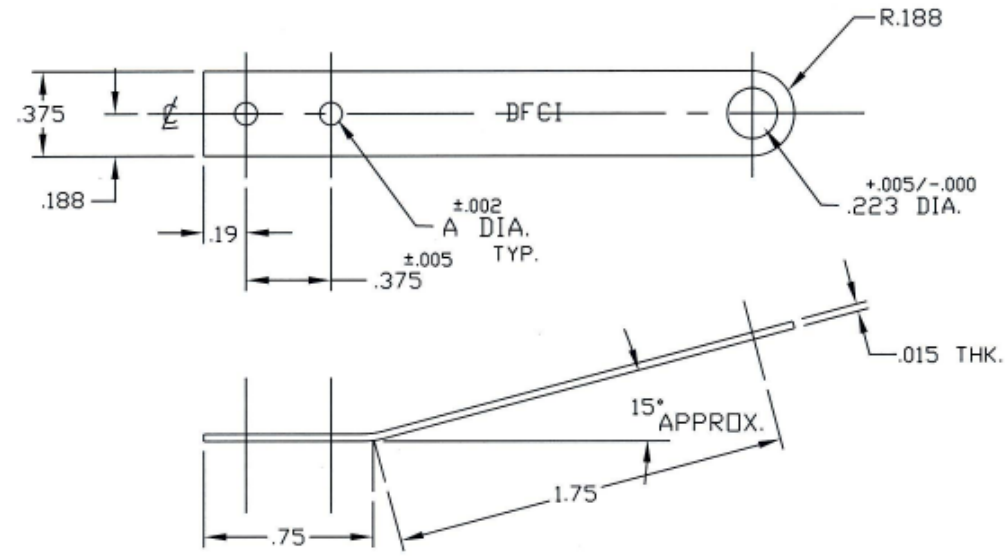

| PART NO. | " A " | WEIGHT (LBS.) | MATERIAL TYPE |
|----------------|-------|---------------|---------------------------------------|
| 1224-1031-SS | .096 | .0040 | TYPE 302, ST, STEEL SPRING TEMPER. |
| 1224-1031-1-SS | .100 | | |

| | | | | | |
|--|--|--|---------------------------------------|--|-------------------------|
| MAT'L AS NOTED. | | TOLERANCES ON DIMENSIONS UNLESS OTHERWISE SPECIFIED X = ±2° .XX = ±.015 X/X = ±1/32 .XXX = ±.010 MACHINE FINISH .125 | | DFCI SOLUTIONS INC. 425 UNION BOULEVARD WEST ISLIP, NEW YORK 11795 | |
| HEAT TREAT NONE. | | PART NO. | DRN <i>S. Francis</i> DATE 1-27-04 | ST-1200 LINE EJECT BLADE, 1224-1031-SS | |
| FINISH CLEAN AND FREE OF BURRS. | | | CHK <i>F. Basile</i> DATE 3/30/09 | SIZE A | FSCM NO 72794 |
| THE FASTENER PARTS SHOWN IN THIS PRINT ARE PROPRIETARY ARTICLES TO WHICH DFCI SOLUTIONS INC. RETAINS THE EXCLUSIVE RIGHTS OF MANUFACTURE, USE AND SALE. THE PRINT OR DRAWING IS SUBMITTED IN CONFIDENCE AND DOES NOT CONVEY A LICENSE OR PERMISSION TO MANUFACTURE THE FASTENER OR FASTENER PARTS. | | | ENG <i>B. Hilde</i> DATE 3/30/09 | DWG. NO. C1224-1031 | REV. D |
| DATE: 07/01/06 FORM: DRAWING | | NEXT ASSY | USED ON | SCALE NTS | WT. |
| COPYRIGHT 2003, DFCI SOLUTIONS INC. ALL RIGHTS RESERVED. | | SALES | DATE <i>B. Hilde</i> 3/30/09 | SHEET 1 OF 1 | |

The parts shown in this print are proprietary articles to which DFCI Solutions, Inc. retains the exclusive rights of manufacture, use and sale. The print or drawing is submitted in confidence and does not convey a license or permission to manufacture the parts. Copyright © 2009 by DFCI Solutions, Inc. All rights reserved.